



Ring Party Training & Judging Seminar

Delegate Reference Booklet

2020

Table of Contents

Course Material and Detail	4
Aim.....	4
Method	4
Certificates	4
Booklet.....	4
The Flyball Lanes	5
Dog Measuring & Height Cards.....	6
Officials required.....	6
Forms required.....	6
C9	6
Procedure	6
Before racing begins	6
Measuring Official.....	7
Height Cards.....	7
Issue of a Height Card	7
Challenging a dog's height	7
Jump Heights	7
Box Judging	8
Where do you sit?	8
Before the race begins	8
What are your duties?	8
Scribing	9
Where do you sit?	9
What do you need?	9
What are your duties?	9
Before each Leg/Race:	9
At the end of each leg:	9
There is no time (N/T)?	10
There is a break-out (BO)?	11
An Average (AVE) is recorded?	11
A loss is recorded for both teams?	11
A tie is recorded?	11
At the end of the race:	11
At the end of each half of the Division:	Error! Bookmark not defined.
Finally:	12
Line Judging	13
Where do you sit?	13
Before the Division starts:	13
At the start of each Leg/Race:.....	13
During the leg:.....	13
At the end of the leg: Check times.....	13
Other requirements	13
Judging a Division.....	14
What do you take into the ring with you?	14
Where do you stand?	14
At the start of the Division.....	14
Before each leg / race	14
Starting a race	14
During each leg/race	14
After each leg / race	15
A race/leg is started when... ..	15
And is finished when... ..	15
BFA Judges: Status	16
Unqualified Members may	16
Provisional Judges must	16

BFA Judges: Qualifications	16
Qualified Judges must	16
Head Judges must.....	16
Additional Responsibilities of the HJ	17
To maintain status	17
C9 - Jump Height Form	18
Single – side Time Sheet (Master)	19
C2 - Team Time Sheet	20
Scenario Discussions	21

Course Material and Detail

Aim To enable all delegates to be confident of the tasks required in all areas of judging for future involvement in BFA Sanctioned competitions.

Method To combine discussion, questions, lectures and demonstrations **(with practical experience)** in all areas of ring partying and incorporating the basic training for those wishing to be provisional judges. Also for those already judging, details will be provided as to the procedures required to apply to become a qualified judge.

Everyone attending this course will have the opportunity to practise their ring party / judging skills and be coached and observed by a Qualified Judge (QJ)/Head Judge (HJ) during the practical session in the afternoon.

During the course, the basic rules of racing will be explained and debated. There will be chances to test your knowledge with some questions / scenarios either during the course or afterwards.

Certificates A **Certificate of Attendance** (not a qualification) will be given to all delegates.

Booklet Please keep this booklet for your future reference.

The Flyball Lane

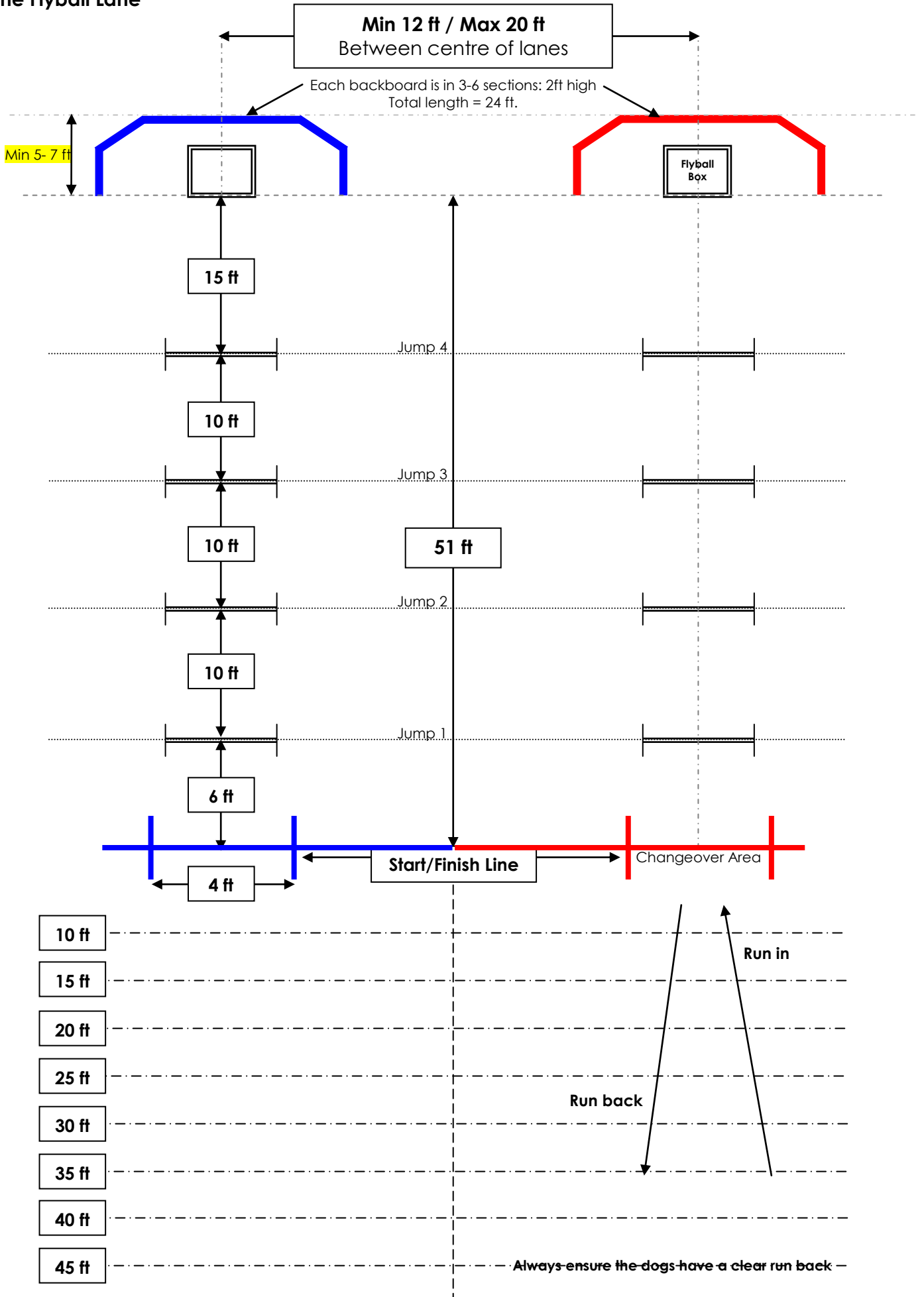

Dog Measuring & Height Cards

Officials required

Takes place normally before racing starts.
 Head Judges and Measuring Officials are qualified to measure dogs. Two Head Judges/Measuring Officials measure dogs that are running at less than 12". All dogs running at less than 12" should be measured if they do not have an official height on the Dog Height Master Sheet.
 All dogs over 36 months of age now have to have an official height recorded on the Dog Height Master Sheet. Once the height card co-ordinator has determined that the necessary criteria has been reached. The measure will be recorded automatically.

Forms required

The Tournament Organiser provides the necessary forms for dog measuring and should also provide a scribe to fill in the details required. The dogs should be measured on a flat, hard surface, outdoors a measuring board is preferable (size at least? Discuss).

C9

The C9 form is used to record all the dogs measured each day of each show. Both measurers must sign the bottom of the form at the close of measuring - no more dogs may be added after this.

This form is available for download at:
<http://www.flyball.org.uk/official/forms/admin/jheight.pdf>

Procedure

One Judge/official measures each dog using BFA authorised equipment. The second Judge/official observes checks the dog's stance is correct and agrees a final measurement. The scribe then fills in the details on the appropriate form.

If there is only one Head Judge/Measuring Official available the dogs can be measured to confirm the height the dog/s is/are running for that day, but the measure will not count towards a height card application.

- ✓ Harnesses/coats shall be removed
- ✓ One handler per dog (unless help is needed)
- ✓ Dog/s must be over 18 months old although younger dogs may be measured for practice, if time allows and the officials are agreeable.
- ✓ The stance: 4 legs squarely, hocks perpendicular to the ground/board; not crouched or stretched with the lead held naturally. (Nervous; lively dogs should be patiently allowed to calm down so that an accurate measurement can be obtained).
- ✓ Each dog is measured from the ground/board to between the withers (shoulders)
- ✓ A dog that cannot be measured, including an aggressive dog, is recorded as not measurable and will jump at the height of the smallest dog in the team (running, not standing by).
- ✓ If the Judge is unable to determine a dog's measurement after 3 attempts the height recorded will be the lowest for the benefit of the dog.

Measuring Official

This is a BFA qualification. To become a Measuring Official:

- ✓ Must be at least 18 years old
- ✓ Must have been a BFA member for at least 3 years
- ✓ Must have competently measured dogs under supervision (MO/HJ) on 5 separate occasions measuring at least 20 dogs in total (including 4 different breeds).
- ✓ Be approved by at least 3 MO/HJ
- ✓ Record evidence on the approved BFA Logbook
- ✓ Head Judges automatically qualify as Measuring Officials.

Height Cards

Issued Height Cards:

- ✓ A list of all BFA official height holders is available to download from the website for public display at their Tournament.

Issue of a Height Card

All height dogs must hold a height card after they are 24 months of age

- ✓ 3 measurements of the same height
- ✓ At 3 different Tournaments
- ✓ With 4 different MO/HJ signatures
- ✓ The dog was at least 18 months old at the first measurement
- ✓ The dog was at least 24 months old at its final measurement (at the height recorded).

If the above criteria cannot be met by 36 months of age then it must be met within the dog's first 10 sanctioned tournaments. Failure to do so shall result in loss of points for the dog and team on the day.

The current BFA Height Card Co-ordinator details can be found [at the foot of the web page] at:

<https://www.flyball.org.uk/bfa-officers-and-committee-members>

Challenging a dog's height

- ✓ Must be made within 30 minutes of the heat in question
- ✓ The Height master sheet/C9 Form will be checked first
- ✓ The dog may be measured again
- ✓ If a measuring mistake has been made there will be no penalty but the team will have to run subsequent heats/races at the correct height.
- ✓ If during racing it is found that a team has been jumping below the correct height, the team will forfeit any races won at the incorrect height.
- ✓ There is no obligation on a Judge to measure a dog again.

Jump Heights

- ✓ Jump height can be adjusted to the height (between the withers) of the smallest dog [running, not on stand by].
- ✓ The minimum height is 6" and maximum is 12" that is adjusted in 1" increments

Box Judging

Where do you sit?

- ✓ At the box end of the lane outside the line of the jumps and box.
- ✓ **Can you see:** the box; the box loader; the dogs coming all the way down the lane and the line of jumps; the line judge?

Before the race begins

The Division Judge will ask the box loaders if they are ready first, then you. Be ready to **clearly** signal your readiness. The Division Judge's whistle will alert you after the warm-up period.

What are your duties?

Check the following:

- ✓ Ball containers and training aids are behind the backboards
- ✓ Watch the box loader's stance - behind the box and (unless actually loading) standing upright
- ✓ The box is positioned correctly
- ✓ Hands and balls are behind the back out of sight
- ✓ The box loader is not distracting the opposing team with loud/aggressive shouting. Verbal encouragement is allowed.
- ✓ The dog triggers the box to release the ball (watch carefully as the dog may steal the ball and trigger the box with its back feet)

What else do I watch for?

- ✓ The dog missing out any jumps
- ✓ The dog dropping the ball on its return up the lane and going back without it
- ✓ The dog may drop the ball and even go back over a jump or temporarily go out of the lane to retrieve it as long as it returns over all 4 jumps
- ✓ Interference - either the dog from 'your' lane or one from the opposing team - (the Divisional Judge makes the final decision)
- ✓ Box malfunction - the box loader may be experiencing problems loading the box; or the ball may pop out of the box before the dog reaches the box. Be ready to stand up with your arms crossed at the wrist above your head to signal the Divisional Judge should the box loader also raise his/her arms above his/her head crossed at the wrist to alert a malfunction.
- ✓ Make sure no-one tampers with the box before the Divisional Judge is able to check it.

Scribing

<p>Where do you sit?</p>	<ul style="list-style-type: none"> ✓ At the start/finish line end of the lane outside the line of the jumps and facing the scribe on the opposite lane. ✓ You sit nearest to the run back area (the Line Judge will be opposite the start line)
<p>What do you need?</p>	<ul style="list-style-type: none"> ✓ The appropriate race sheet (C2) for your lane - Check you have the correct sheet.
<p>What are your duties?</p>	<p>Before each Leg/Race:</p> <ul style="list-style-type: none"> ✓ Check you have the correct paperwork ✓ Circle around the appropriate number 1 - 6 for the four dogs running in each leg (Team Captains should inform you - if not ask!) ✓ Check the jump height is correct according to which dogs are actually running ✓ Keep an eye open for interference in the run back area. <p>Check break-out (BO) times on the racing sheet:</p> <p>(A) Divisional BO times will apply to all teams running under their current seed or declared time [e.g. if the top seeded team in the division has a seed time of 18.56, the <u>Divisional Break-out Time</u> will be 18.05 - i.e. faster than, not equal to half a second faster than the top seeded team's seed time]. <u>Note</u>: Division 1 teams are not subject to division BO.</p> <ul style="list-style-type: none"> ✓ (B) Declared times : With the exception of Division 1 a team running more than half a second faster than its declared submitted time will be the loser of that heat. <p>At the end of each leg:</p> <ul style="list-style-type: none"> ✓ LISTEN to the Judge who will inform of any No Times etc ✓ On team's racing sheet - record the time for that lane; and circle, whether it was W (won), L (lost), or; T (tied) <p>Single sided sheets may still be used by Tournament Organisers however it is no longer a requirement.</p>

What if: There is no time (N/T)?

It's important to record **WHY** on the racing sheet.... for example:

- ✓ "N/T" = Not all 4 dogs completed / re-ran
 - ✓ "INT N/T" = The offending dog is from the team on 'your' side
 - ✓ **If a dog on your side interfere with a dog from the other team the Judge will ask you to put the dogs's number, as listed on the C.2 into the box for interference INT (This will be either dog's numbers 1 to 6)**
- "INT AVE 4" = The offending dog is from the opposing team (average time of 4 dogs racing will be calculated by Stats)
- "INT AVE 5" = The offending dog is from the opposing team (average time of 5 dogs racing will be calculated by Stats) - this is because the team that was 'interfered with' already had one fault light, at the point of interference, so would have had to re-run the faulted dog, had racing proceeded without interference - e.g. a total of 5 dogs would have run to successfully complete racing in that lane... and so on).

There is a break-out (BO)?

- ✓ Inform the Divisional Judge
 - ✓ Tick the B/O box on the C2 sheet
 - ✓ The time is recorded and counts towards the team's FUTURE seed time however **BO times will not be used for team placing in the event of a tie.**
 - ✓ **The team that broke out will LOSE THAT LEG, despite finishing first.**
 - ✓ 3 break-outs and the team is disqualified, but may continue racing
- Note: Dogs racing in a team that has broken-out 3 times (or more in a day of Division racing) can still accumulate their BFA points, so long as the team competes in each remaining race of the day; but the team will not be eligible to win the division (e.g. they will automatically be placed last in the division, so long as there are no other teams that break-out 3 times or more within their division). All previous wins will convert to losses and wins recorded for their opponents.

An Average (AVE) is recorded?

- ✓ **AVE 4** = 4 dogs completed BUT, the timing equipment stopped or malfunctioned. Also if there is an interference that stops the race from completing.
- ✓ **Ave 5/6** = This is recorded where a 5th or 6th dog ran and the team completed but the timing equipment stopped or malfunctioned. And as above.

A loss is recorded for both teams?

It is possible for a LOSS to be recorded against both teams if:

- ✓ **A Not for Competition (NFC) team** runs against **1.**a team presenting with less than 4 dogs (only 3 legs should be run); **2.**a team that has already broken out 3 times; **3.** A team that breaks out (single leg)
- ✓ Both teams break out
- ✓ Both teams have faults but **refuse** to re-run their dogs to attempt to win

A tie is recorded?

It is possible for teams to tie if:

- ✓ Both teams have the same time to 2 decimal places; (an extra leg is run)
- ✓ Both teams fail to complete and it wasn't possible to determine a winner (rarely used but it allows changes of dogs - an extra leg is run). This is recorded as a No Time tie.

At the end of the race:

- ✓ Any alterations are initialled by the Division Judge
- ✓ Circle the **W** or **L** (win or loss) for the race result as appropriate and document the time of the fastest leg

Check that everything that should be, is completed

Pass the clipboard with the (C2) sheet on it to Admin and collect the C2 form for the next race.

- Finally:**
- ✓ Work as a team with the Division Judge and your Line Judge - e.g. Be aware of the racing.
 - ✓ If in doubt - ASK!

Line Judging

Where do you sit?	<ul style="list-style-type: none"> ✓ At the start/finish line end of the lane outside the line of the jumps and facing the line judge on the opposite lane. ✓ You sit nearest to the box opposite the start line ✓ Ensure you have a clear view of the start/finish 'gates, the racing lane and the box judge.
Before the Division starts:	<ul style="list-style-type: none"> ✓ Make sure you are familiar with the lights system being used - if in doubt ask the Division Judge. ✓ With your scribe, go through the pre-race checks.
At the start of each Leg/Race:	<ul style="list-style-type: none"> ✓ Signal clearly to the Division Judge when asked that both you and your scribe are ready ✓ If on the lane with the control of the starting light sequence - on the signal from the Division Judge, set the timing sequence in action to start the leg
During the leg:	<ul style="list-style-type: none"> ✓ Switch on the individual dog's light if the dog faults in any way ✓ Switch off the individual dog's fault light when the dog has re-run (in the correct order) and completed successfully. ✓ If the Judge stops the race with a whistle signal for: False start; Interference; Accidents; Any conditions causing a safety hazard - stop the timing system and re-set the light system. <p>Watch out for:</p> <ul style="list-style-type: none"> ✓ Early change-overs and handlers triggering the lights ✓ Dropped balls ✓ Dogs missing out the starting gate and any jumps ✓ Jumps knocked over creating a safety hazard - (if the Division Judge blows their whistle to interrupt racing for any reasons) stop the timing system and re-set the light system ✓ The box judge indicating any faults
At the end of the leg: Check times	<ul style="list-style-type: none"> ✓ Give the time to the scribe (depends on whether there are external timers) ✓ If the heat is close, determine which team has won ✓ If a team has broken-out, inform the Division Judge (some judges ask that this is done by turning all 4 fault lights on) <p>Also:</p> <ul style="list-style-type: none"> ✓ Let the Division Judge know if a team has not completed.
Other requirements	<ul style="list-style-type: none"> ✓ Have a sound knowledge of the rules of racing (Section 5) ✓ Work with the Division Judge, Box Judge and Scribe as a team!

Judging a Division

What do you take into the ring with you?

- ✓ Your good character
- ✓ Stopwatch and whistle
- ✓ Confident body language
- ✓ A thorough understanding of the sport gained through personal experience
- ✓ Knowledge of the rules of racing
- ✓ Fairness
- ✓ Common sense
- ✓ Initiative
- ✓ The right attitude: Friendly, courteous, but impartial and firm
- ✓ Your smile
- ✓ A Provisional Judge has a Supervisory Judge (QJ or HJ)

Where do you stand?

- ✓ Centrally in the run back area so that you can see; both boxes; all other Judges; the finish line; the lights - try to also be aware of the run back area and any interference that may take place in this area. Also ask your scribes to keep watch on the run back area.

At the start of the Division

- ✓ Check the lanes and jumps
- ✓ Check ring party are familiar with their duties and check if there are any break out times to be aware of.

Before each leg / race

- ✓ Check jumps

Starting a race

- ✓ Check boxes are in position, ball in cup
- ✓ Ask box loaders, box judges, line (lights cleared; scribe has dogs to race ringed on racing sheets) and finally teams if they are ready
- ✓ Signal appropriate line judge to start the time sequence
- ✓ Keep your whistle in your mouth so that you can indicate a false start quickly.

During each leg/race

- ✓ Blow whistle to stop race due to false starts; knocked down/blown over jumps (if necessary); interference (if necessary); or any other hazard.
- ✓ Keep a careful watch for any infringements and signal clearly which lane has faulted
- ✓ Allow an interfered with dog to have a re-run first, and any interfering dog second (if team/handler wish)
- ✓ Allow a dog that has knocked down a jump to re-run (if team/handler wish)
- ✓ Check with teams if they wish to re-run a faulting dog
- ✓ Place a yellow 'peg' on the T-pole to indicate which team has a false start

**After each leg /
race**

- ✓ Blow whistle to end each leg and the end of the race
- ✓ Give clear information to Ring Party
- ✓ Put 'peg' onto T-pole to indicate each leg winner
- ✓ Clear any False Start 'pegs' after the race has finished
- ✓ Start stopwatch for 2 minute warm-up once both boxes from previous race have been lifted/removed.

**A race/leg is
started when...**

- ✓ The light sequence (or manual count-down) begins

**And is finished
when...**

- ✓ The Division Judge blows the whistle and declares a winner.

What if: False Starts?

- ✓ Each team is allowed one false start per race*. Whistle to stop racing and re-start the leg.
- ✓ *However, if one team already has a false start and on the re-start **both teams or the other team** false start, whistle to stop racing and re-start the leg.
- ✓ Except for the situation* above, once the dog has false started if it does so again in that race, it must re-run after the 4th dog has completed.

I'm not sure who has won the leg?

- ✓ Use your Ring Party to help you - they are part of your team.
- ✓ Ask the Supervisory/HJ Judge for advice. (The final decision though is yours!)
- ✓ Explain to both teams your reasoning - especially if you need to re-run a leg and aim to get both Team Captains' agreement.

Neither team can complete?

- ✓ Division Judge stops the race and either awards the leg to the team that has completed the most, or awards a No Time tie.

This allows:

- ✓ The teams to put in alternative dog/s (if available)
- ✓ The Judge to prevent dog/s compounding their problem
- ✓ The Judge to prevent 'training in the ring'.

I make a mistake?

- ✓ Apologise - PLUS, if you need to reverse a decision, explain to both teams your reasoning.

A dog faults during racing?

- ✓ It may re-run after the 4th dog has completed, in the same order that it ran originally (e.g. if dog 2 and dog 4 both fault, dog 2 must re-run before dog 4)
- ✓ Teams may choose not to re-run dogs
- ✓ Watch carefully that dogs do not keep being re-run in a leg...
 - (A) It can just compound the problem
 - (B) It could be counted as 'training in the ring'.

BFA Judges: Status

<p>Unqualified Members may</p> <ul style="list-style-type: none"> ✓ Act as a Box Judge; Scribe ✓ Act as Line Judge when they have gained experience and knowledge of racing rules. Having a mentor to support them initially is good practice. ✓ All line and box judges within the ring must be 14 years of age or over, unless directly supervised by an additional adult member. (i.e. not supervised by the line judge or scribe). <p>Provisional Judges must</p> <ul style="list-style-type: none"> ✓ Be supervised at all times by a QJ/HJ ✓ Be at least 16 years old - If under 18 years old, must be supervised from within the ring. 	
---	--

BFA Judges: Qualifications

<p>Qualified Judges must</p> <ul style="list-style-type: none"> ✓ Be 18 years of age ✓ Have completed 5 assignments each of: Box Judge, Scribe, Line Judge for a minimum of 12 races. ✓ Have completed 10 Provisional Judge assignments ✓ Be recommended by 3 Head Judges (not from own team) ✓ Pass a novice judge exam on Section 5 (Rules for Competition) of BFA Rules ✓ Provide evidence of the above to be recorded on the BFA approved form ✓ Be a member and in good standing with the BFA for 18 months ✓ May remain as a Qualified Judge and not go forward to become a Head Judge. <p>Head Judges must</p> <ul style="list-style-type: none"> ✓ Be a Qualified Judge (QJ) and have completed at least 10 Division Judging appointments as a QJ. ✓ Be a QJ for at least 3 years. (Log books will not be issued until applicants have been a Qualified Judge for 3 years) ✓ Be a member in good standing with the BFA. ✓ Be a member/dog handler ✓ Apply to the BFA Judges Board to be considered as a Trainee Head Judge <p><u>Also:</u></p> <ul style="list-style-type: none"> ✓ Their Log Book is used to record the successful achievements of the criteria ✓ The Log Book is returned to the BFA Judges Board when completed ✓ Complete successfully the criteria within 2 years of application ✓ Attend a BFA Judges Seminar ✓ Take and pass a written examination ✓ Have completed the criteria to become a Measuring Official, this will be in the log book. 	
--	--

<i>Additional Responsibilities of the HJ</i>	Head Judges also take on the added responsibilities of: <ul style="list-style-type: none">✓ Dog measuring✓ Head Judge at a show✓ Supervising some Provisional Judges/Qualified Judges
<i>To maintain status</i>	All Qualified Judges & Head Judges must: <ul style="list-style-type: none">✓ Attend a judges seminar every 2 years✓ Maintain judging assignments✓ Keep pace with any BFA rule changes

Provided overleaf are copies of the official BFA Forms mentioned within this Training Booklet, all of which can be downloaded from the BFA website using the provided links.

Single Side - Time Sheet (Master) – Use of this sheet is optional and is not bt the Stats Officer

6 TEAM ROUND ROBIN

DIVISION

Race No	TEAM Blue Lane	Break-out Time	TIME	TIME	TIME	TIME	TIME	TIME	TEAM Red Lane	Break-out Time	TIME	TIME	TIME	TIME	TIME	TIME	
1																	
2																	
3																	
4																	
5																	
6																	
7																	
8																	
9																	
10																	
11																	
12																	
13																	
14																	
15																	

Scenario Discussions

In your group please study the following scenarios, individually decide who (may be more than one member of the ring party) is responsible for the decision and discuss in your group what you think the decision should be. On the paper provided please make a note of the decision/s and how many 'voted' for each decision.

1. A jump is knocked over. A) It remains straight but moves 4ft towards the next jump b) the jump is knocked right out of the racing lane.
2. The Judge, having asked the start dog handlers, signals the line judge to start the race but the blue lane captain protests that their team were not ready.
3. The blue light is switched on after the 3rd dog does an early change. The team re-run the 2nd dog (as signalled) and beat the other team back.
4. Something very unusual happens in a race. The divisional judge, having not met this situation before, is unsure whether there is a rule covering it.
5. A dog has collected the ball from the box but drops it between 2 jumps – a) stops before the line goes back to collect the ball and finishes with the ball in its mouth b) As above but the dog's nose crosses the line prior to its turn.
6. The judge has checked that both box loaders and box judges and line judges are ready, then turns to ask the teams if they are ready. While the Judge's back is towards them a) one of the box loaders waves the ball at the start dog unseen by the judge b) on turning back the judges sees the box loader waving the ball.
7. The red lane team has finished with 4 clean runs but the blue lane is re-running a dog. One of the red team dog's get in the way of the re-running blue team dog.
8. The Tournament Organiser has not designated a warm up time limit. The blue lane team has completed its warm up but the red lane team continues to do their warm up for some while and the judge decides to whistle for end of warm up. The red lane team protests loudly that they haven't finished their warm up.
9. The race has finished and both teams have left the ring a) when the line judge informs the division judge that he/she failed to signal a dropped ball due to discussing this with the scribe as he/she was not sure. b) the judge overhears the 'offending' team outside the ring rejoicing that they had got away with a win.
10. A dog starts its run, jumps over the first jump, returns over the first jump but not through the line, then turns back towards the box and completes its run.
11. The line judge starts the countdown sequence in error before the judge has signalled for the start.
12. A division has started and race 3 is about to commence when the red lane captain goes to the scribe to add /change a dog.
13. A 7 team division is running and is at race 11. The red team have arrived, warmed up and are ready to race. The blue lane team have not arrived in the ring.
14. The red team member 'doing the line' thinks that the scribe has made an error so leans over the scribe, deletes what the scribe has done and changes it to what he/she believes to be correct.
15. The judge has blown the whistle to signal the end of the race and moves to one side of the lanes as the teams leave the ring. One of the blue lane team decides that as their dog made an error, they will give it a correctional run before leaving the ring. The judge turns and sees the dog start to run so stands in the lane in front of the start gates.



©British Flyball Association 2020 - All rights reserved.

No part of this document may be reproduced or transmitted in any form or by any means, electronic or mechanical, including photocopying, recording, or any information storage or retrieval system without prior written permission from the British Flyball Association.